

CAD FILE:

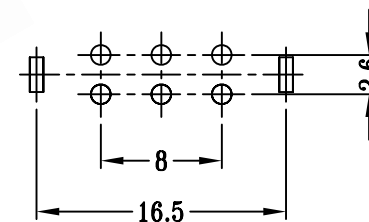
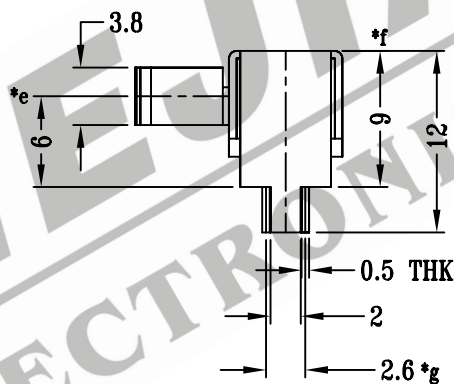
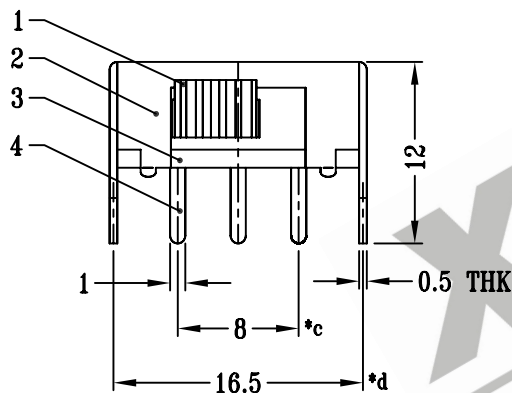
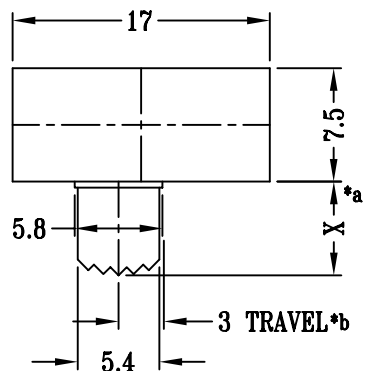

SCHEMATIC (NON-SHORTING)

P.C.B LAYOUT

注:带*表示关键尺寸(7个)

NO.	PARTS	MATERIALS	Q'TY	FINISH	TOLERANCE UNLESS SPECIFIED	SHENZHEN XIEJIA ELECTRONICS CO.,LTD.							
8					WITHIN: 1.5 ±0.1mm	ISSUE	DATE	DESCRIPTIONS OF REVISION		APPD.			
7				OVER: 1.5 ±0.2mm									
6	SPRING	STEEL WIRE	2	TEMPER	TITLE : HORIZONTAL SLIDE SWITCH MODEL: SK-22F02 ALL MATERIALS MUST BE COMPLIANT TO ROHS								
5	CONTACT	COPPER	2	Ag PLATED						UNIT : mm	DRWG NO.: XJ-DR-SK22F02-00		
4	TERMINAL	BRASS STRIP	6	Ag PLATED OVER Ni PLATED						SCALE: 2:1	DWN.	ZHOUYU	2003-11-22
3	BASE	PHENOLIC RESIN	1	BLACK						CHK'D	FANGYING	2003-11-22	
2	FRAME	STEEL STRIP	1	Ni PLATED						APPD.	KANGXINAN	2003-11-22	
1	KNOB	POM	1	BLACK									